

Bias Control System Assembly & Instruction Manual

I. Introduction

Thank you for your purchase of our **BCS Output Tube Bias Control System**. It solves the most pressing concern for tube amplifier owners – setting and keeping set the output tube(s) bias current. Users can ALWAYS be sure that the “tube bias setting” is always under control and perfectly set. Our BCS constantly monitors and controls the bias of each individual output tube - independently. There is no longer any need to pay a premium for matched tube sets or worry about tube aging. The system compensates for all of these variables. It has been designed and refined with premium components and instrumentation grounding / signal transmission technology to deliver instrument grade performance. It is important that you follow our instructions carefully to take advantage of this technology.

This document describes the specific instructions and steps associated with the **BCS Output Tube Bias Control System project**. Take note of the document revision as identified in the title block above. In addition, I recommend that you visit our web page and download the following tech notes:

- a. General Overview Assembly Notes (CAE Tech Note # 1)
- b. Soldering Tutorial (CAE Tech Note # 2)
- c. Recommended Tools & Test Instruments (CAE Tech Note # 3)

These documents have been prepared from our own assembly experience and will greatly cut your chances for error if not to make the project much more fun. Of particular importance are the use of quality tools and soldering procedure

In the following sections we will guide you through several project phases. Each section has been carefully prepared with our own notes and comments from our customers to be sure that any anticipated question has been considered. The sequence is identical to that which we follow when we complete the fabrication for our customers. Please follow the same sequence to maximize efficiency and eliminate errors. It is also very helpful to read each section before beginning to gain a visual idea of the construction.

Your project will be built in stages. First you will assemble and prepare the pc board module(s). This is a very important project phase as the board modules contain nearly all of the circuitry for your project. There are several important factors to remember:

- a. **Proper soldering is crucial.** Please refer to our soldering tutorial and practice on surplus boards until you master the technique. Be especially careful to avoid solder bridges or “cold” solder joints. Our experience shows that nearly **95% of all problems are associated with soldering related errors**.
- b. Diodes, transistors, IC’s, (all semiconductors) and many capacitors (always electrolytic types) are polar - this means that **there is a right and wrong way to insert polarized components in the board**. If placed backwards, the component and probably others nearby will be damaged upon initial power application. Double check each step associated with these parts and once again later after you have had a chance to take a break.
- c. Some components are color coded with their value (mostly resistors, but there may be others). If you are not proficient at reading these codes, use your digital voltmeter to double check the value of each resistor before insertion. It is very easy to confuse a 100 ohm metal film resistor with a 1000 ohm resistor or worse with a 100K ohm resistor.

Once completed, the boards will be placed into the chassis and wired to each other and the associated panel mounted components (switches, connectors, transformers, output tubes, etc.)

Next, you will prepare the amplifier chassis. This phase may involve the removal of old parts and pc boards and will certainly include preparation of the chassis for the new boards and or parts. You can take advantage of the stripped down chassis to access tight nooks and crannies that would otherwise be difficult

to reach and clean dirt and grime that may have accumulated over time. New hardware, connectors and pc boards are then installed.

Next, the newly installed connectors, sockets and pcb boards will be connected followed by a visual inspection before power is applied.

Finally, you will initially apply power and take the initial measurements and complete any adjustments.

An Important Note About Internal Wiring

Unless otherwise specified, **you should use 20 to 22 gauge stranded wire with teflon insulation.** The Teflon will permit you to apply sufficient thermal energy to the solder connection for proper solder joint formation without worrying about melting the insulation. Thicker wire or solid wire will cause problems - if not now (too much strain on the boards or parts) or later (reliability issues). I really can't overemphasize the importance of this advice.

In many cases you will be directed to "prepare" a length of wire. The preparation process requires you to take 3 steps: 1) Cut the wire to the length indicated, 2) Strip ¼" of insulation from each end and, 3) "Tin" each end of the wire. Please don't try to save time by skipping the tinning step.

In some cases we have specified connections be completed in pairs (2 wires). In these cases you will use a pair of wires together to make an electrically related connection (such as signal + and signal -). It is much easier to prepare a master length of pairs at the beginning of your project and then when required, cut the designated length from this master. For the MQ-100 project, we recommend that you prepare two lengths (one for each amplifier) of 15 foot black / white twisted pair. To prepare a master pair, use the following method:

1. Take the ends of the wires in the group and clamp them in a pair of "vice grip" or other device that can secure the ends of the wires firmly. Now, secure the vice grip.
2. Take the other ends of the wires in the group and stretch them to about 10% greater than the desired length. Cut them at that point and then place them in the jaws of a ¼" variable speed drill. Make sure all wires are of equal length - and while keeping the group taut, begin to slowly twist the assembly. Continue slowly until the turns ratio is about 2 to 3 turns per inch.
3. While keeping the twisted group taut, run your hand along the length of the assembly to stress relieve the elements.
4. Let the assembly sit for about 5 minutes and then release.

During the assembly process when you are directed to use twisted pairs, simply cut the length designated and strip ¼" insulation (unless otherwise directed) and "tin" each conductor.

II. Printed Board Assembly

Before you begin assembling your BCS pc board, you should take time to establish a location for mounting on (or in) your amplifier. The assembly can be mounted above or below chassis and can be mounted either horizontally (using spacers) or vertically (using angle brackets). If you are installing inside a Dyna Stereo-70, I recommend placing it under chassis in the position originally occupied by the 7 pin terminal strip (below the left channel output transformer). Depending on your ST-70, there may be room above chassis between the power transformer and driver pc board. In the Dyna MK-3, under chassis is recommended – you can mount either horizontally or vertically.

Locate the board (blank or assembled) and find an appropriate position on your amp. Once you have settled on a location, mount the spacers or angle brackets as needed to support the board. It may be necessary to drill new mounting holes (1/8" drill to accommodate 4-40 hardware) – use the board as a template.

In any case, be sure to remember that the board will require about 5/8" of clearance to clear some of the capacitors. You may also want to be sure that you have reasonable access to the adjustment pot after the board has been mounted in place.

OK – now on to assembling the pc board. Refer to Figure 1a or 1b – PC Assembly Diagram

Unless otherwise noted, components are to be inserted on the non-foil side and soldered on the foil side. The sequence of assembly has been chosen so that the components with the lowest profile (such as jumpers, low power resistors, IC's etc.) are installed first with higher profile components added until the highest profile components are installed last.

You should begin by getting the parts list for this board, opening your kit and grouping the components into categories as follows:

1. PCB Turrets
2. ¼ Watt Resistors (Metal and Carbon Film)
3. PCB Jumpers
4. ****** Diodes (Signal, Power, Zener)
5. ****** IC Socket
6. ****** Signal IC (14 pin dip)
7. Small Capacitors (disc, silver mica, polystyrene etc.)
8. ****** Small Signal Transistors & IC's (Plastic Packages such as TO-92)
9. Pots
10. Power Resistors (1, 2, 3 and 5 Watt Resistors)
11. ****** Power Transistors (TO-220 Metal Tab & Plastic Body) – Future Use in this Project
12. ****** Electrolytic Capacitors (Always Polarized)
13. Hardware (Spacers, Angle Brackets, etc.)

Note that this is a generic list – your project may not have all of the groups listed. **The items tagged (**) are polarized – during installation on to the pc board, you must be sure they are installed correctly and positioned as shown in the diagram.**

Now that you have grouped the items, note that they are grouped in similar physical sizes with group 1 being the smallest and progressing upwards to the larger components. Your assembly of the pc board should begin with the items in group 1 and proceed sequentially upwards to the larger components. Note that unless otherwise notes, the components will be mounted on the non-foil side of the board and solder terminated on the foil side. There are two Assembly diagrams – one showing the top view components by Name, the other showing the component Values. You may use either as you find convenient. In both cases the diagrams are full size so they may be used to precisely locate specific components.

Refer to Figure 1 – PC Assembly Diagram

- I do not recommend using pc board turrets rather I recommend placing a pool of solder onto each terminal pad and placing each associated wire into the molten pool (parallel to the pc board surface) – this will result in a solid reliable connection. However, if you are using pc board turrets (connection or test terminals), they should be installed now. You will need to drill out the terminal pads to the diameter of the turret diameter. This project has 10 external connections. The turrets should be held in place for soldering using an auto punch to flare out the base (on the foil side) before soldering
- Next install all of the non-power resistors (¼ Watt). Refer to the color code diagram to help you identify the resistor values. Additionally, I recommend using a digital multimeter to confirm value before insertion into the pc board. You can install most (if not all) of the resistors on the board and bend the leads of the resistors outward to keep them in place until you solder the entire group at one time. If desired, you can separate this into smaller groups to facilitate soldering. Save the cut leads from the resistors to be used as pc jumpers in the next step.
- ** Polarized Component Alert** – Install all of the diodes next. This includes 5 signal, two power and one zener diode - they are all essentially the same package (about the size of a ½ watt resistor) BUT they have a band indicating their cathode lead. Be sure you identify the correct part (you will have to look carefully to locate the part number on the body of the part) and install as shown in the assembly diagram.
- You can now install all nine ceramic capacitors. There are five 0.1uF caps and four 1000p (1nF) caps.

- **** Polarized Component Alert** – If you are using a 14Pin DIP IC socket for your IC, it should be installed next. This is polarized and will have an indicator to indicate correct orientation. Several indication methods are used (depending upon the supplier. Most will have a small “half moon” cutout on the “pin1 & pin8” end. Look carefully for the designator and install as indicated. If unsure, please send an e-mail to discuss. Once installed, you may insert the associated IC now. Note also that the IC is also polarized so that there is only one correct orientation. The IC will have an indicator near Pin1-Pin8 end that can take the form of a “half moon” or a small circle at the Pin 1 position. Again, if unsure, please send an e-mail to discuss.
- Install the small capacitors next. This includes all of the radial leaded ceramic disc capacitors.
- **** Polarized Component Alert** - Install the four small signal transistors (plastic packages) next. The packages used in this project are both the TO-92 (half moon) package. **The Power Tab (TO-220 package is optional and is not used in this project.** Be sure you confirm the part number on the part before placement. These devices are shaped in a semi-circle - the flat end should be positioned as shown in the assembly diagram.
- Next install the 1K / 3 Watt Metal Oxide power resistor. It should be mounted so that there is approximately 1/4” space between the component body and the pc board surface. This aids thermal dissipation.
- Next install the BIAS SET (P1) potentiometer. The pot used in this project is roughly square and is supplied in the vertical orientation package. It is to be installed in a specific orientation as dictated by it’s three leads.
- **** Polarized Component Alert** – Install all three electrolytic capacitors next. The electrolytic capacitors used in this project are all in radial lead packages. Carefully examine each capacitor - one lead (usually the negative lead, but not always) should be clearly marked – sometimes with a black stripe or designating arrow (usually pointing to the negative lead). **Be sure you have identified the leads correctly** – this is critically important with electrolytic capacitors. Insert the part as described on the assembly drawing – the positive lead is indicated in the assembly figure with a “+” symbol. Solder the parts into place and as a final QC, perform a visual inspection to be sure that the parts are installed correctly.
- All of your electrical components should now be installed. Depending on the amplifier and mounting scheme, you can now install any remaining hardware items such as mounting spacers or angle brackets.
- Prepare approximately 5 feet of BLACK / WHITE twisted pair of 22ga Teflon wire. Prepare also approximately 1.5 feet of RED / BLACK twisted pair (22 ga Teflon wire). The best way to facilitate this is to place the ends of both leads in the chuck of your drill and, while holding the wires are the other end under tension, twist until you have approximately 2-3 turns per inch of twist.
- Take your completed BCS board and temporarily mount in the location you previously selected.
 1. Take the BLACK / WHITE twisted pair and strip 1/8” of insulation from both the black and white leads (on one end), tin (always tin before your make wire connections) and connect the WHITE wire to BCS board “G1 and the BLACK wire to BCS board “K1. With the BCS board in place route cleanly to V1. I recommend that envision the distance as a collection of vertical and horizontal runs (as opposed to diagonal runs). Add 2” and cut. Label this TP (twisted pair) V1.
 2. Repeat step 1 again for V2 (WHITE wire to “G2” and BLACK wire to “K2”) with TP labeled as V2.
 3. If you have a ST-70, repeat step 1 again for V6 (WHITE wire to “G3” and BLACK wire to “K3”) with TP labeled as V6.
 4. If you have a ST-70, repeat step 1 again for V7 (WHITE wire to “G4” and BLACK wire to “K4”) with TP labeled as V7.
 5. Next, take your RED/BLACK twisted pair, strip the 1/8” of insulation from both the Red & Black leads (on one end), tin and connect the Red wire to BCS board terminal “R-B” and the Black wire to BCS terminal “GND”. With the BCS board in place route cleanly to the location of the stock selenium rectifier located near the center of your Dynaco amplifier (looks like a stack of rectangular plates). Add an additional 2” and cut.

III. Chassis Preparation

Before you install your Bias Control System Module, it is necessary to prepare your amplifier to tie into your amplifier. Note that while the BCS is compatible with any fixed bias output tube amplifier (those having bias adjustment pots) of up to four tubes, I have included diagrams and specific instructions to support the Dynaco Stereo-70 and Dynaco MK-2/3 power amplifiers. If you are installing in another amplifier you can make the same connection to your output tube cathodes and grids as is described here.

Preparation will essentially involve:

1. Modifying the output tube(s) existing cathode bias resistor setup – removing two (perhaps four resistors) and then adding new resistors (in the end you will have one resistor per output tube).
2. Removing the bias injection resistors from the driver board (pc board with small tubes) – these are 1/2 Watt resistors ranging from 100K to 470K ohm and usually located near the short edge(s) of the pc driver board(s).
3. Removing the stock bias supply (selenium rectifier, 2 filter caps, and associated bias power supply resistors – and at you discretion, the original User Bias pots.
4. Adding, if needed, 3 pin terminal strips to support the power amplifier connection.

To modify the output stage, we'll remove the old output tube cathode bias resistors and replace with new 5.6 ohm / 1Watt resistors. In the end, you will have added one 5.6 ohm / 1Watt resistor for EACH output tube. Refer to Figure 2a (for Stereo-70) or Figure 2b (for Mark 2/3). Changes are noted underlined and in **RED**.

- In both the MK-2/3 and ST-70, remove the wire connecting V1 Pins 1&8 to V2 Pins 1&8.
- Remove also the original cathode bias resistor – in ST-70's this is 15.6 ohms and in MK-2/3's it is a 11.6 ohm resistor. Note that depending on how the amp was wired, one side of this resistor can be connected to either V1 Pins 1&8 OR V2 Pins 1&8 – regardless, remove and replace with one of the supplied 5.6 ohm 1Watt resistors.
- Add another 5.6 ohm / 1Watt resistor to the remaining output tube Pins 1&8.
- If your amp is a ST-70 repeat the previous 3 step for the V6 & V7 output tubes (as shown in Figure 2a).

Now we'll remove the original bias injection resistors located on the driver board (pc board housing small driver tubes). There is one resistor for each output tube so in the ST-70 there are four 270K ohm resistors and in the MK-2/3 there are two 100K ohm resistors. To locate these bias injection resistors first locate the User Bias set pot. In the ST-70, there are two pots (one for each channel) and they are located near the center of the chassis – in the MK2/3 there is one pot located near the output tubes.

- For each bias control pot, locate the center lug and the wire attached. Follow that wire to where it connects to the driver pc board (board with small driver tubes).
- From this connection, follow the foil on the pc board and you will find the ends of the 2 associated bias injection resistors. Remove them – you can de-solder or if your board foil is questionable, simply cut them out.
- On the ST-70 you will need to do this for both channels - for each bias control pot (2).

Next, we will now remove all of the stock bias supply circuitry (this is all replaced with your BCS module). Removal involves the elimination of the stock selenium rectifier, filter caps (2) and other associated resistors.

- First, you will need to remove the original bias rectifier – in stock Dyna amps it looks like a stack of rectangular plates with two terminals and a clearance mounting hole down the center. In both the ST-70 and Mark-2/3 it is located near the center of the chassis. De-solder the power transformer ~~Yellow-Red~~ Red-Black (stripe) lead and cut any remaining wires or component leads. Remove and discard the stock selenium rectifier.
- In place of the stock selenium rectifier, mount a three pin terminal strip. Connect the power transformer ~~Yellow-Red~~ Red-Black (stripe) lead de-soldered in the prior step to one of the outer terminals of this 3 pin terminal strip. Be sure that you do NOT make this connection to the ground (mounting) terminal but only to one of the floating outside terminals.
- Next, remove the two bias filter caps. These are axial leaded components, cylindrical, and approximately 1” in diameter & 2” long. In the ST-70, they are mounted on the 7 pin terminal strip located under the left output transformer. In the MK-2/3, one cap is connected to the stock selenium rectifier and a 3 pin terminal strip near the fuse. The other is connected directly to the bias adjustment pot and V2 ground lug. Remove and discard them both.
- Finally, remove the two bias power supply resistors. In the ST-70, these are located on the 7 pin terminal strip below the left output transformer. In the Mk-2/3, one is connected to the 3 pin terminal strip near the fuse. The other is connected to an outer lug of the Use Bias adjust pot and Ground lug on V3.
- The stock User Bias pot will no longer be active and therefore you may remove or retain for aesthetic purposes.

OK –Your chassis is now prepared for the installation and final wiring of your BCS module.

IV. BCS Output Tube Bias Control System Module Installation & Final Wiring

Locate your assembled BCS Module. You should have already fabricated the 4 (2 for MK-2/3) BLACK/WHITE twisted pair connections and the single RED/BLACK twisted pair connection to the terminals on this module. You should also have already installed the mounting hardware to your amplifier so that your BCS board is ready to install.

- Physically install the board to the location you have selected. Route all of the twisted pair wires neatly aiming towards their associate end termination points (output tubes and power transformer center).

Refer to Figure 3a (for Stereo-70) or Figure 3b (for Mark 2/3). Changes are noted Underlined and in **RED**.

- Locate the BLACK / WHITE twisted pair (TP) labeled V1. Route cleanly to output tube V1, trim to length and connect the WHITE wire to V1 Pin 5. Connect the BLACK wire to V1 Pin 1&8.
- Locate the TP labeled V2. Route cleanly to output tube V2, trim to length and connect the WHITE wire to V2 Pin 5. Connect the BLACK wire to V2 Pin 1&8.
- If you have a Stereo-70 - Locate the TP labeled V6. Route cleanly to output tube V6, trim to length and connect the WHITE wire to V6 Pin 5. Connect the BLACK wire to V6 Pin 1&8.
- If you have a Stereo-70 - Locate the TP labeled V7. Route cleanly to output tube V7, trim to length and connect the WHITE wire to V7 Pin 5. Connect the BLACK wire to V7 Pin 1&8.
- Locate your ~~RED/WHITE~~ RED/BLACK twisted pair. Route cleanly to the location of the three pin terminal strip that replaced your original selenium rectifier. Connect the RED wire to the same terminal as the power transformer ~~Yellow-Red~~ Red-Black (stripe) lead. Connect the Black lead to the mounting (this should be the ground terminal) of the same 3 pin terminal strip.

V. System Checkout

The purpose of this section is to perform a cursory check on the assembly and installation of your BCS module. Additionally, we will make the initial adjustment of the BIAS SET Pot (P1 located on the BCS board). First phase will be to take resistance measurements – in all cases you will be measuring from the point indicated to system ground (chassis). The second phase of tests will apply power to your amp and monitor the DC Voltage at several test points - this should provide a pretty good indicator that it is operating correctly. Finally, you will adjust the BIAD SET Pot (P1) – the only adjustment necessary for the BCS system. This adjustment sets the level of the current that will flow in all of the output tubes controlled by the BCS system (although each tube is monitored and controlled individually there is a common set point for all tubes).

You will be using a common Digital Voltmeter (DVM) to measure resistance as well as DC and AC Voltages. All tests will have you connect the **Black Lead** of your DVM to ground (chassis). Resistance measurements are indicated in OHMS or KOHMS. Voltage measurements are indicated in DCV (DC Volts) or ACV (AC Volts). Please adjust your meter accordingly.

SAFETY NOTICE

To avoid personal harm and/or equipment harm, you must take the following preparations & precautions:

- Before you begin these tests and measurements, and/or following any step where the amp is powered, you must WAIT 20 MINUTES to be sure all amplifier capacitors have been discharged.
- Remove all tubes – small signal tubes, output tubes & rectifier tube (5AR4/GZ34 in Dynaco amps).
- Rotate the BCS Module Bias Adjust Pot (P1) FULLY COUNTERWISE (as seen from the components side of the board).
- Temporarily replace the power fuse – use a 0.5AMP SLO-BLO fuse
- Familiarize yourself with the test point locations on the BCS module (see Figure 1b)
- All resistance tests must be made without power applied. It is a good idea to have the line cord unplugged just to be certain.
- Voltage tests will be made with the power applied. By removing the tube rectifier the DC high voltage will be disabled however very high AC voltages will still be present near the tube rectifier socket – use the appropriate safety precautions.

Resistance measurements are performed without power and uses resistance measurements to identify any gross errors. Be sure to set you DVM to the resistance position. The resistance values shown are not exact (the reading you get will have a direct relationship to the brand and model of DVM you are using) therefore it is not critical that the reading be exact but rather that there are no significant differences. Be concerned only if your measurement is significantly different than indicated.

Refer to Figure 1b. With the negative (**BLACK**) lead of your DVM connected to the Ground (chassis) and using your DVM **RED** test lead, make the following measurements and observations:

- BCS Terminal GND = 0 ohms
- BCS Terminal R-B = < 100 ohms
- BCS Terminal G1 = > 220K ohms
- BCS Terminal G2 = > 220K ohms
- BCS Terminal G3 = > 220K ohms
- BCS Terminal G4 = > 220K ohms
- BCS Terminal K1= 5.6 ohms (+/- 1 ohm)
- BCS Terminal K2= 5.6 ohms (+/- 1 ohm)

The next two measurements are applicable only to Amplifiers using all four channels (such as the Dyna ST-70):

- BCS Terminal K3= 5.6 ohms (+/- 1 ohm)
- BCS Terminal K4= 5.6 ohms (+/- 1 ohm)

The next set of tests involve taking **Voltage Measurements** – they are performed with power applied. **Warning: Lethal voltages will be present during the subsequent tests.** You must exercise the greatest care to avoid any contact with any components. Your **BLACK** DVM lead will be connected to the amplifier chassis. Your **RED** DVM probe is the only item that makes connection to the amplifier under test.

Be sure to set your DVM to the DC Volts (NOT AC Volts) position. Except for the BCS Bias Pot (P1) Adjustment, the voltages given are not exact (the reading you get will have a direct relationship to the brand and model of DVM you are using) therefore it is not critical that the reading be exact but rather that there are no significant differences. Be concerned only if your measurement is significantly different than indicated.

Refer to Figure 1b. With the negative (**BLACK**) lead of your DVM connected to the Ground (chassis) and using your DVM **RED** test lead, make the following measurements and observations:

- Test Point (TP) 1 = + 70 VDC +/- 10 VDC (Positive voltage)
- Test Point (TP) 2 = - 70 VDC +/- 10 VDC (NOTE: Be sure this is a Negative Voltage)
- Test Point (TP) 3 = + 16 VDC +/- 2VDC (Positive voltage)
- Test Point (TP) 4 = Adjust BCS Bias Control Pot (P1) for a reading of **0.252 VDC (252 mV DC)**. Note that this is a critical setting and will set the current flowing thru all of the tubes under BCS management. Note that this voltage setting represents a current of 45mA thru each output tube. If you wish to have a higher (or lower) bias current flowing the you can calculate the Voltage setting for P1 by using the formula $V \text{ (volts)} = 5.6 \times \text{Desired Current (in Amps)}$. (Note 1 Amp = 1000 mA)
- Once you have successfully passed the previous Resistance and Voltage tests, you should power down your amp and wait several minutes.

System Operation Tests

- Insert the Rectifier tube
- Insert ONE of your Output Tubes. Place it in position V1.
- Connect the **BLACK** lead of your DVM to chassis ground. Connect the **RED** lead of your DVM to V1 Pins 1&8. Make sure your DVM is set to the DC Volts measurement selection and that you can resolve accurately 0.5 Volts (500mV) – usually this is the 2Volt range selection – but not always.
- Apply power and monitor the voltage on your DVM. After approximately 10 to 40 seconds, the voltage reading should begin rising and settle at about 0.252 Volts DC (252 mV) +/- 50mV. Watch this very closely - it will overshoot for a few second perhaps up to 0.500 Volts (500 mV) however if it continues to rise above 0.500 VDC quickly remove power. Once you have confirmed that the voltage has stabilized in a safe range you can trim the BIAS SET Pot (P1) on the BCS module to the correct voltage (252mVDC or 0.252 VDC).
- Once you have successfully completed the first system operation test, it is likely that the system is functioning as designed however it is a good idea to verify the operation of each output tube position. To do this, power down and allow the amp rest un-powered for several minutes. Repeat the test as described in the previous step but with the single output tube placed in the remaining output tube sockets (V2, V6 and V7) individually each time allowing several minutes for the amplifier to rest between each subsequent test. If you have trimmed the BIAS SET Pot (P1) above, there is no need to re-trim again.
- Finally, once all of the System Operation Tests have been completed, you can replace the power fuse with the specified fuse (3A Slo-Blo in Stereo-70) and insert all of the amplifier tubes.

Congratulations – your BCS is now installed and ready to provide you with years of worry free tube operation.

VI. Troubleshooting

Should any of the tests fail to provide the results defined, you should immediately stop and begin to diagnose the problem. Going further is certain to cause additional problems.

Nearly all of the problems encountered with initial start up are related to poor connections and soldering. Therefore it is imperative that you visually examine all of your connections. If any connection appears suspect follow the instructions in our soldering tech note to repair the connection. Pay particular attention to possible solder bridges especially on the BCS module especially near the wire termination points.

The second most troublesome problem is with components that have been inserted incorrectly (polarity). Be sure the diodes, transistors, integrated circuits, and electrolytic capacitors are in the proper location and correctly oriented. Once again a visual inspection compared against the stuffing guide will resolve a great number of problems.

Finally, on several occasions, we have seen components installed that are not the correct value. This is most common with color coded parts such as resistors. For example a 100 ohm 1% metal film resistor has color bands - brown/black/black/black/brown while a 1000 ohm 1% metal film resistor has color bands - brown/brown/black/black/brown. It is very easy to confuse the two.

If you assembled your pc boards as suggested (in component type groups) hopefully you measured the value of each resistor with your ohmmeter before insertion as described. Also check capacitor values carefully. It would be easy to mistake a 0.001 uF disc capacitor with a 100 pf capacitor.

Infrequently wiring errors arise. If you have confirmed the previous items you can begin checking suspect wiring by either 1) tracing each wire mechanically or 2) by resistance checks with you ohmmeter set to its lowest setting. Look for 0 OHMS from end to end. If you obtain a reading of 10 ohms or so you are probably not looking at the same lead. Where you have used twisted groups be sure you have not interchanged the wiring. This is most common with twisted pairs where the "WHITE" lead is reversed with the "BLACK" lead. Check for 0 OHMS readings from closely adjacent PC board terminals to check for solder bridging.

Once you have located a suspect component(s) always power down and wait 20 minutes for the electrolytic capacitors to discharge - then replace the part. During the process be careful not to disturb the wiring - always examine the integrity of the wiring after you have made the repair to avoid creating additional problems.

If you should encounter a defective part, be sure to consider both the cause and the effect. If for example you find an overheated resistor, consider what may have caused it to overheat and replace that part as well.

These steps will usually resolve 90 % of all problems. However if you prefer not to get into this kind of diagnosis, please feel free to call us for preparation for return to our lab for resolution.

Figure 1a – BCS Assembly (Component Names)

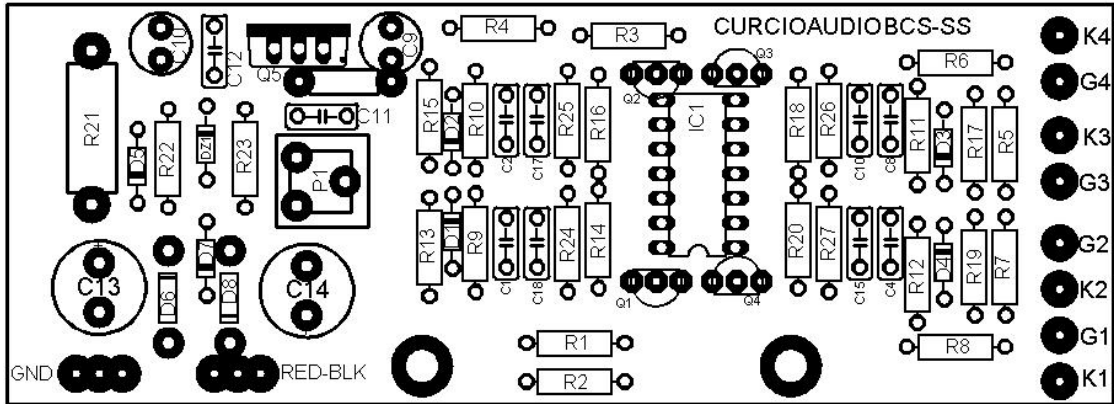

Figure 1b – BCS Assembly (Component Values) & Test Points

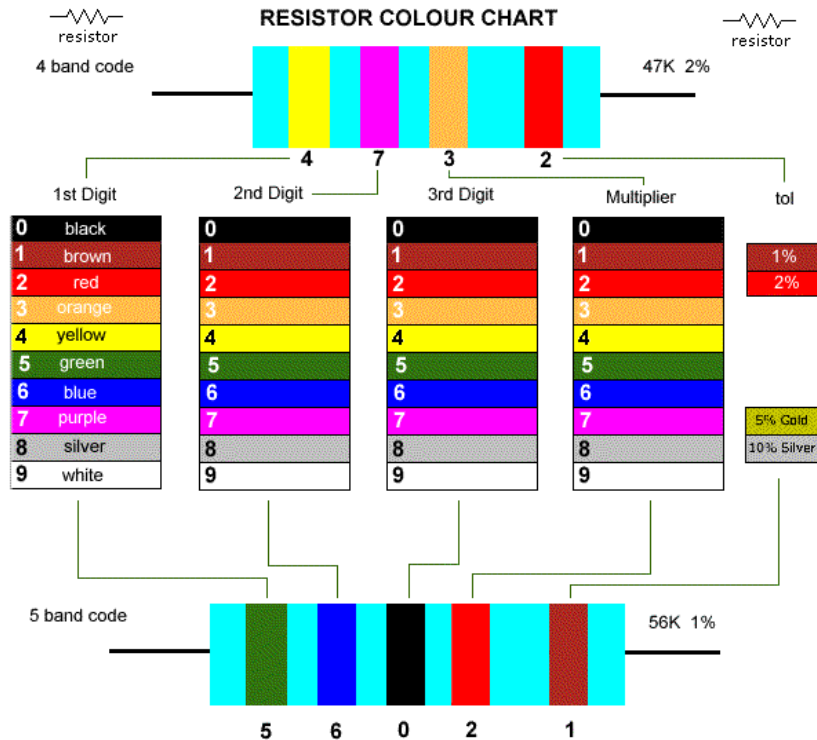
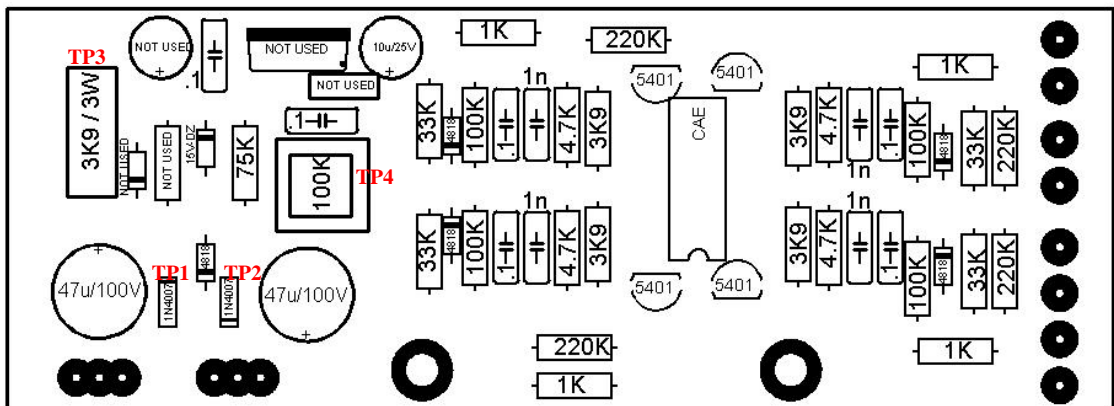

Figure 2a – Dynaco Stereo 70 Output Tube Resistor Modifications

Figure 2a Dynaco Stereo-70 Bias Control System Bias Resistor Modifications

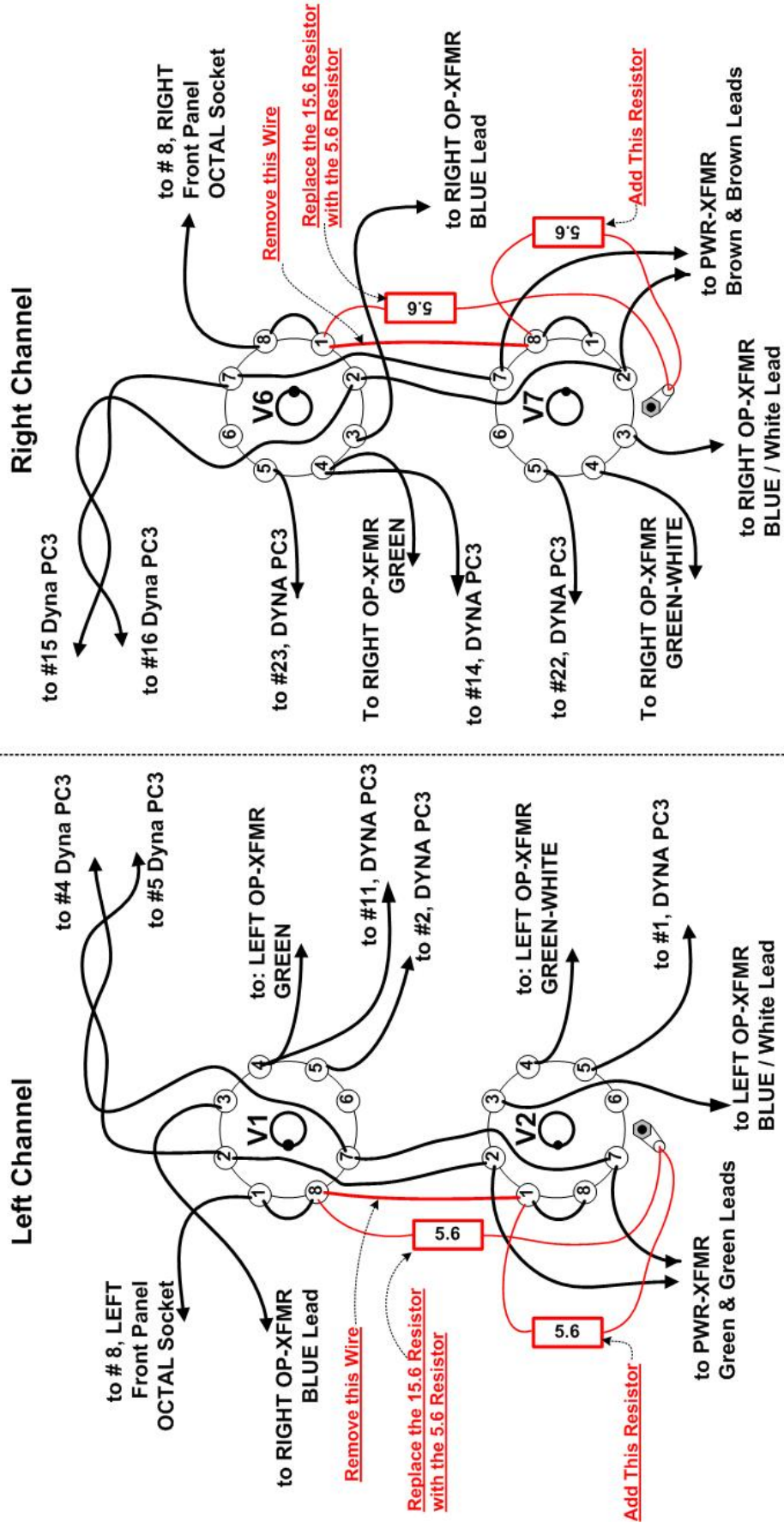

Figure 2b – Dynaco Stereo Mark 2/3 Output Tube Resistor Modifications

Figure 2b Dynaco MK-3 Bias Control System Bias Resistor Modifications

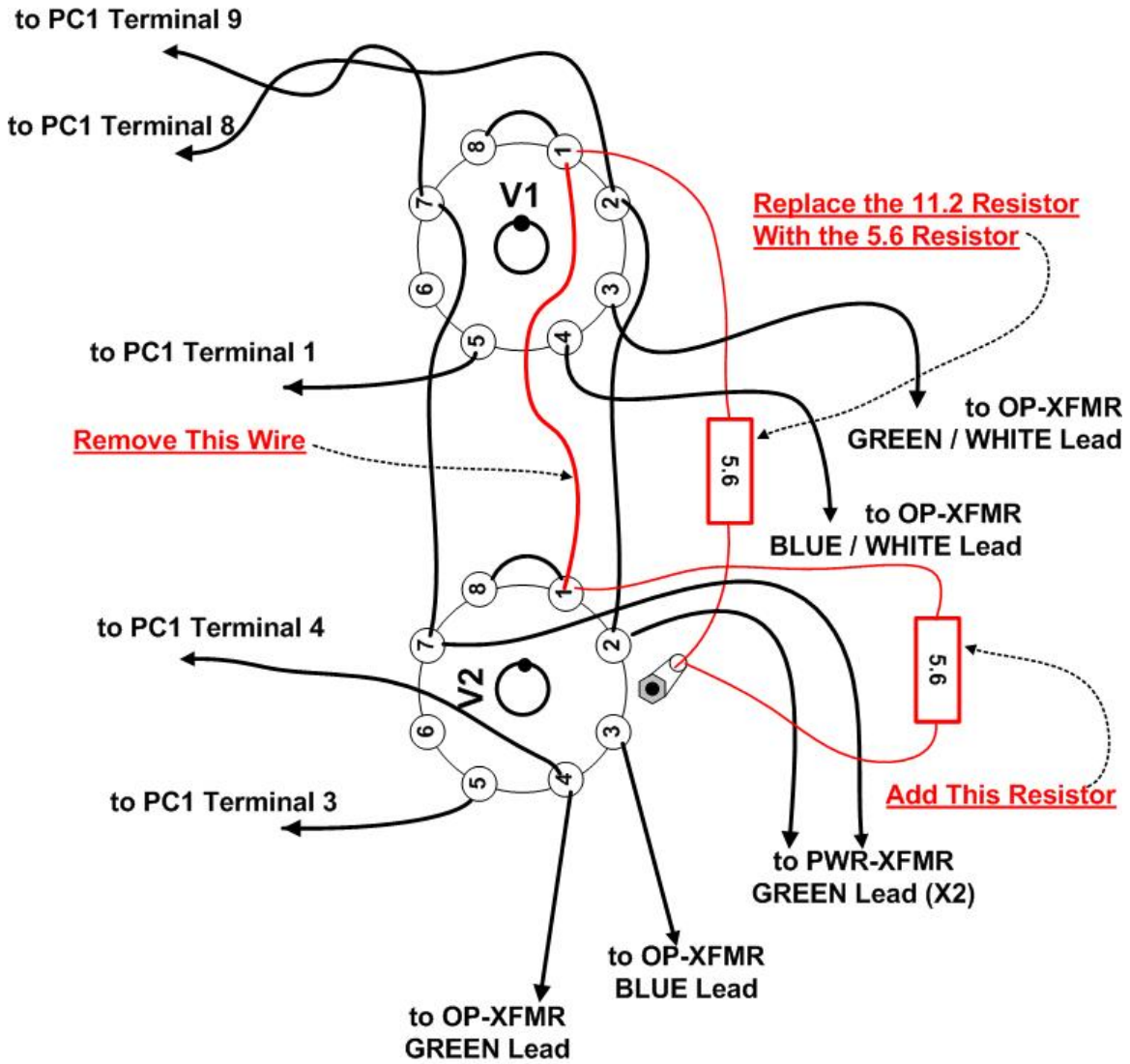

Figure 3a – Dynaco Stereo 70 BCS Output Wiring Diagram

Figure 3a Dynaco Stereo-70 BCS Output Tube Wiring Diagram

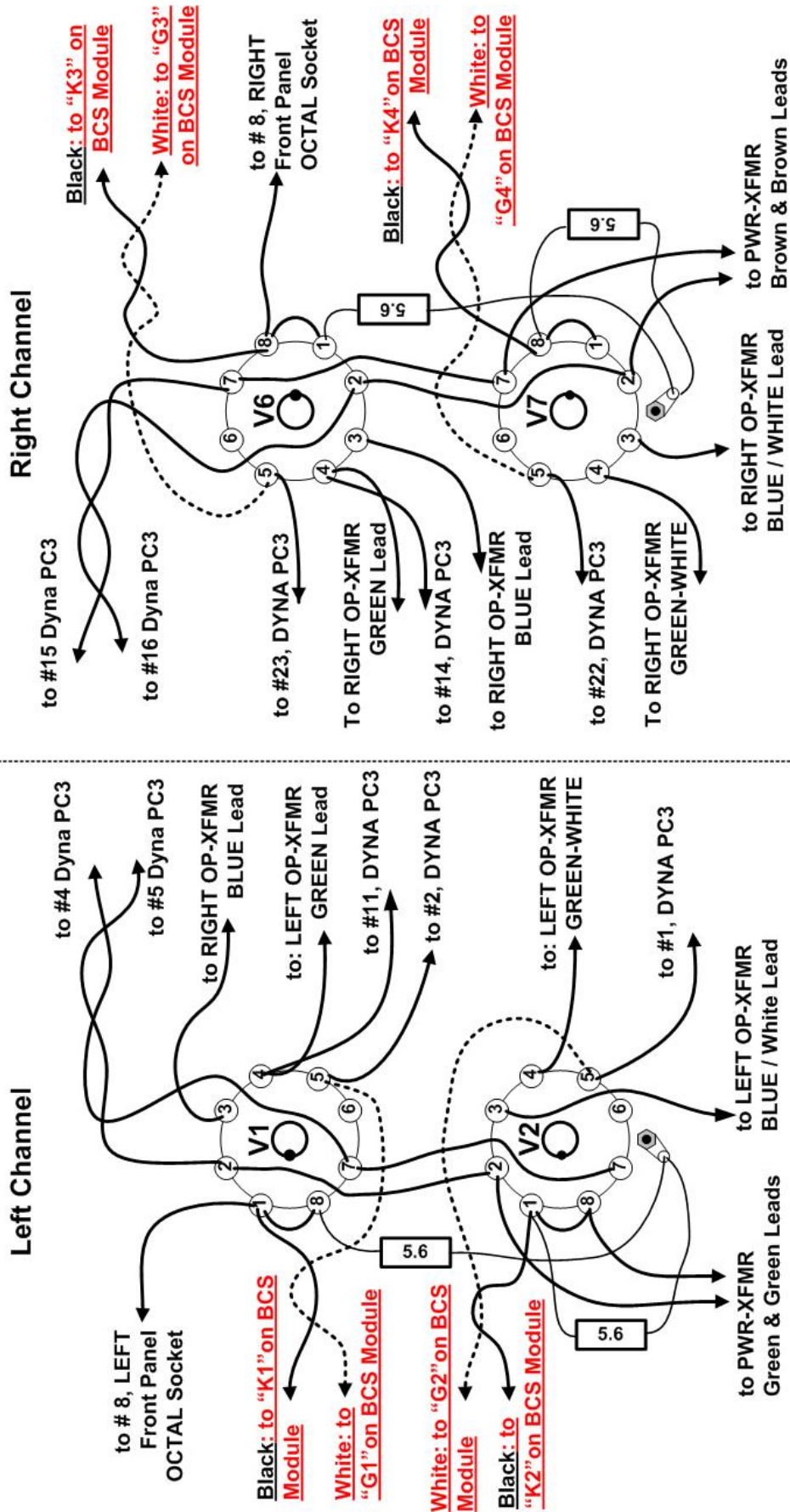

Figure 3b – Dynaco Stereo 70 BCS Output Wiring Diagram

Figure 3b Dynaco MK-3
BCS Output Tube Wiring Diagram

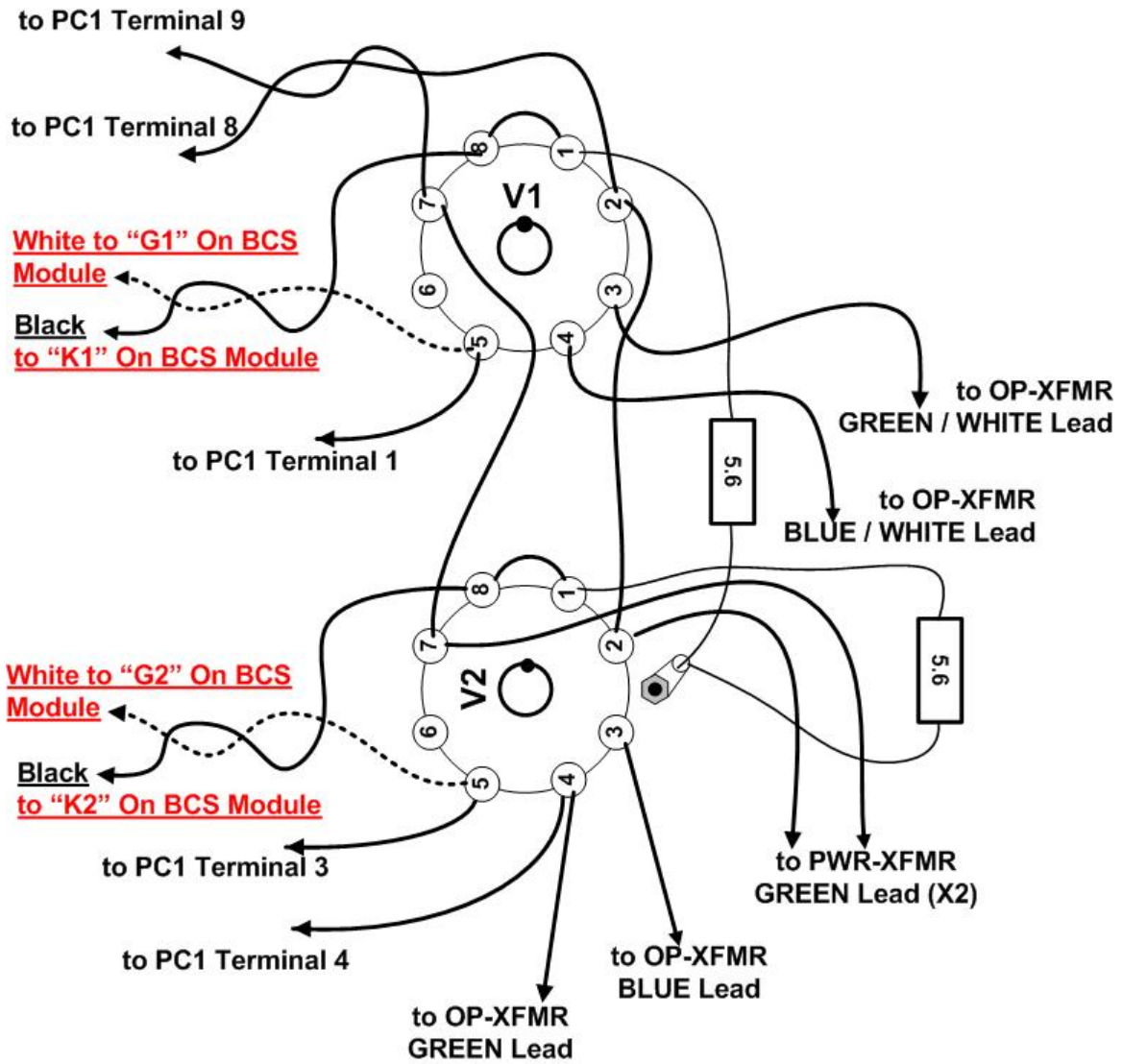
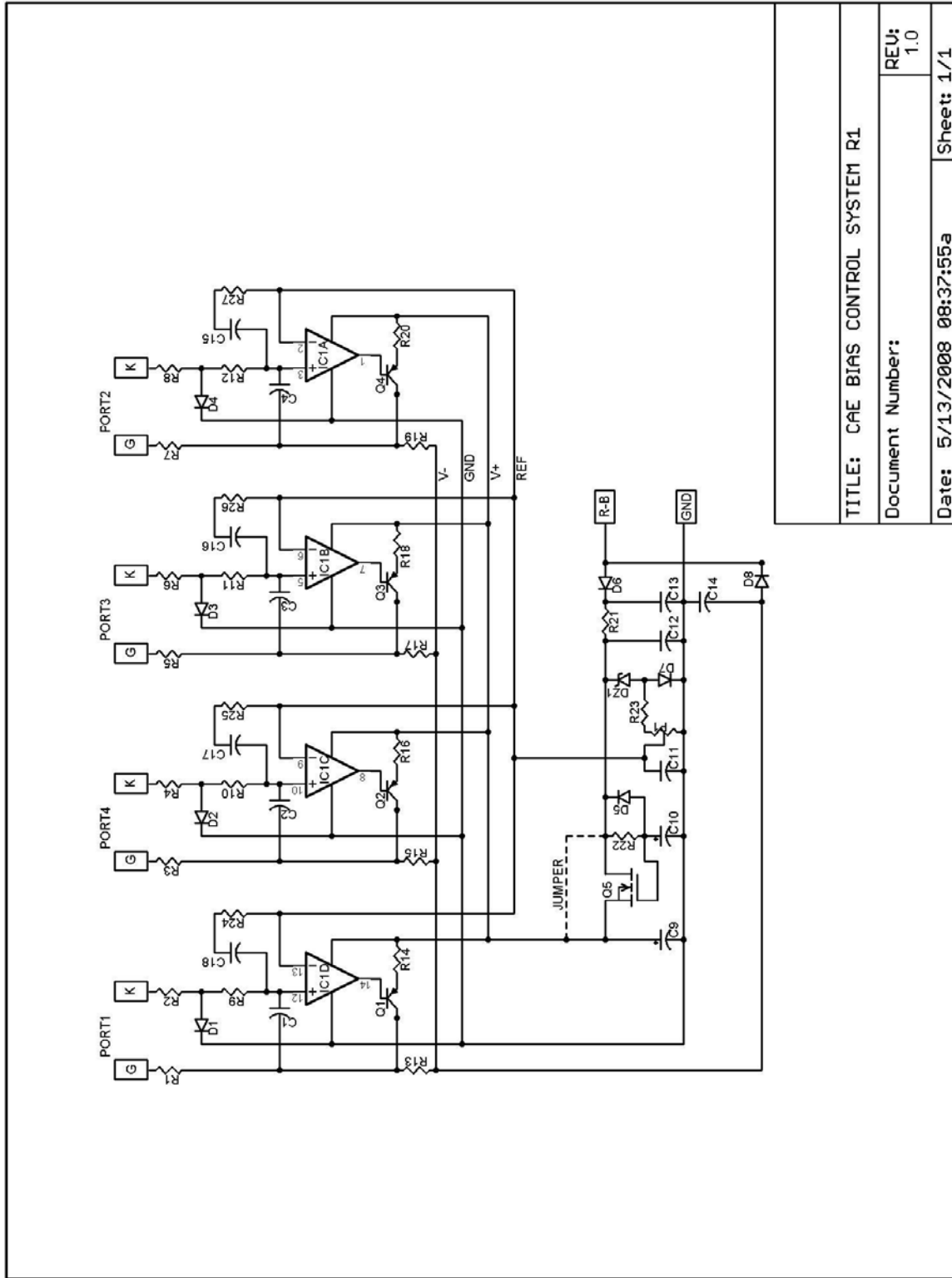

Figure 4 – Bias Control System Schematic Diagram



TITLE: CAE BIAS CONTROL SYSTEM R1

Document Number:

REV:
1.0

Date: 5/13/2008 08:37:55a

Sheet: 1/1

Figure 5 – Bias Control System Bill of Materials

CAE Output Tube Bias Control System

R1a

ABS Power Amp Output Tube Bias Control System CAE# ASM-BCS

PAGE 1 of 1

DESIG	DESCRIPTION	QNT Y	PART NUMBER	VAL / VOLT
C1 - C4, 11	CAPACITOR, DISC (RADIAL)	5	MSR#BQ74D0474K	0.1uF/100VDC
C5-C8 (Not Used)	CAPACITOR, DISC (RADIAL)	0	CAE# R100V.47	0.47uF/100VDC
C9	CAPACITOR, ELECTROLYTIC (RADIAL)	1	MSR#140-XRL25V10-RC	10uF / 25VDC
C10 (Optional)	CAPACITOR, ELECTROLYTIC (RADIAL)	0	MSR#140-XRL25V100-RC	100uF / 25VDC
C12 (Not Used)	CAPACITOR, DISC (RADIAL)	0	MSR#BQ74D0474K	0.1uF/100VDC
C13, C14	CAPACITOR, ELECTROLYTIC (RADIAL)	2	MSR#140-XRL100V47-RC	47uF/100VDC
C15 - C18	CAPACITOR, DISC (RADIAL)	4	MSR# 140-100Z5-102Z-RC	1000p / 100VDC
D1 - D4, D7	DIODE, SIGNAL	5	MSR#1N4148	1N9418
D5 (Optional)	DIODE, SIGNAL	0	MSR#1N4148	1N9418
D6, D8	DIODE, POWER	2	MSR#583-1N4007	1000 V / 1A
DZ1	DIODE, ZENER	1	MSR#583-1N4744A	15V / 1 W
IC1	CONTROL AMPLIFIER, QUAD	1	CAE# IC-BCS	
P1	POTENTIOMETER, PCB HORZ	1	MSR#531-PT6KV-100K	100K
Q1, Q2, Q3, Q4	TRANSISTOR, PNP	4	MSR#512-2N5401TA	2N5401
Q5 (Optional)	TRANSISTOR, MOS-FET	0		IRF-710
R1, R3, R5, R7	RESISTOR, CARBON FILM	4	MSR#291-220K-RC	220K - 0.25 W
R2, 4, 6, 8	RESISTOR, CARBON FILM	4	MSR#291-1K-RC	1K - 0.25 W
R9, 10, 11, 12	RESISTOR, CARBON FILM	4	MSR#291-100K-RC	100K - 0.25 W
R13, 15, 17, 19	RESISTOR, CARBON FILM	4	MSR#291-33K-RC	33K - 0.25 W
R14,16,18,20	RESISTOR, CARBON FILM	4	MSR#291-3.9K-RC	3.9K - 0.25 W
R21	RESISTOR, MET OXIDE	1	MSR#283-3.9K-RC	3.9K, 3W
R22 (Optional)	RESISTOR, CARBON FILM	0	MSR#291-1.0M-RC	1MEG - 0.25 W
R23	RESISTOR, CARBON FILM	1	MSR#291-75K-RC	75K - 0.25 W
R24, 25, 26, 27	RESISTOR, CARBON FILM	4	MSR#291-4.7K-RC	4.7K - 0.25 W
X1	PRINTED CIRCUIT BOARD	1	B-BCS-SS-r1	
X2	TERMINAL STRIP, 3 PIN	1	CAE#TS-3	
X3	THREADED SPACERS	2	MSR # 534-2202	4-40 x 1.25 "
R-OT Cathode	RESISTOR, MET OXIDE	4	MSR# 282-5.6-RC	5.6 OHM, 2W

NOTES : CAE# - Curcio Audio Part Number
 DK# - DigiKey Part Number MSR# - Mouser Part Number

Figure 6 – Stock Dynaco Stereo 70 Wiring Diagram

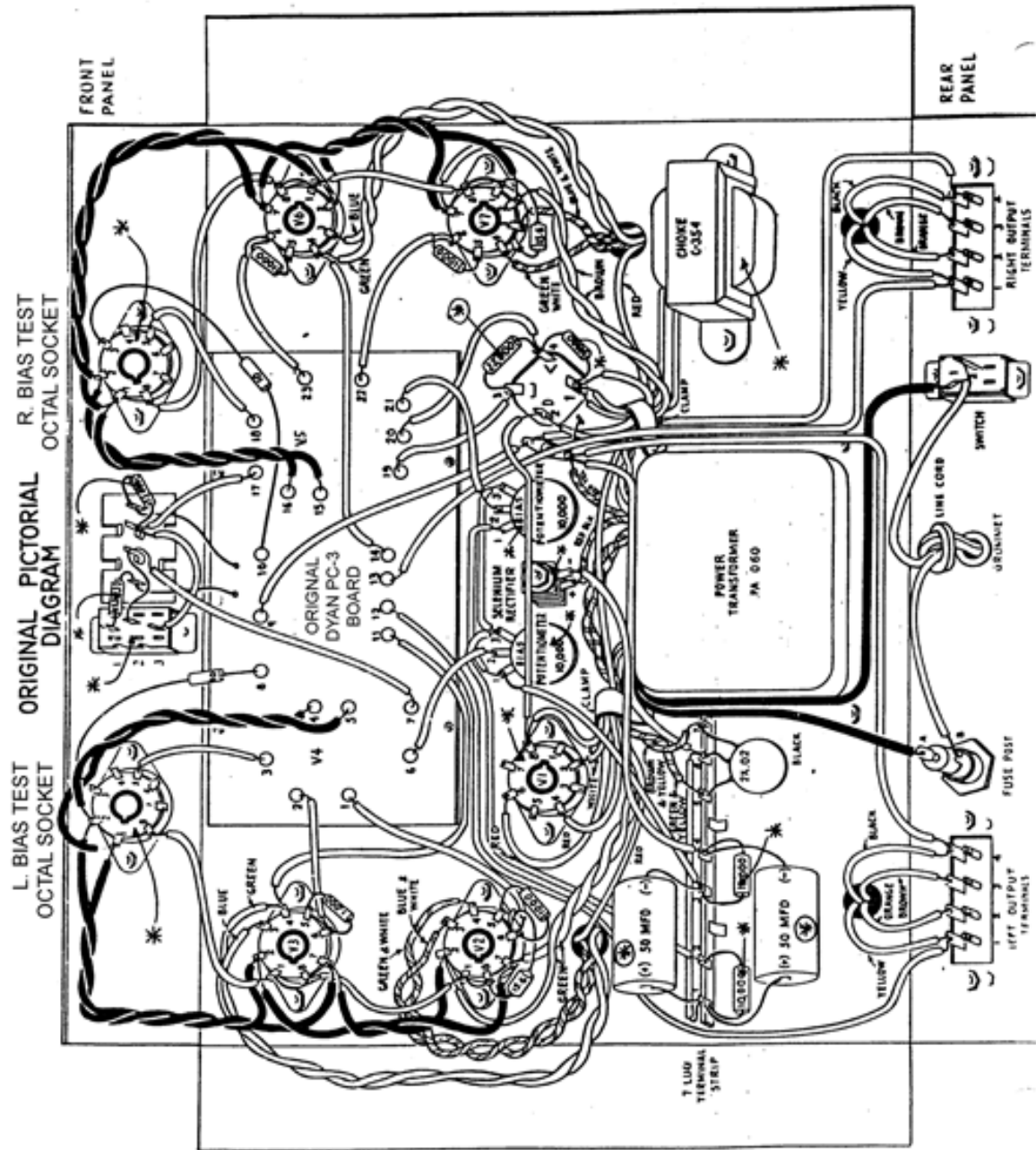

Figure 7 – Stock Dynaco Mark 2/3 Wiring Diagram

