

dynakit

SERIAL NUMBER

This number must be mentioned in all communications concerning Dynakit.

INSTRUCTIONS FOR ASSEMBLING DYNAKIT MARK IV



Price \$1.00

PATENTED

07010

DYNA COMPANY **DYNACO**

3916 POWELTON AVE.
PHILADELPHIA 4, PA.

INSTRUCTIONS FOR ASSEMBLING DYNAKIT MARK IV

DESCRIPTION

The Mark IV Amplifier uses a circuit arrangement based on that of the Dynakits Mark II and Mark III which have become world famous for superior quality while essentially simple and trouble free. The new 7199 tube is used as a pentode high gain voltage amplifier directly coupled to a cathodyne phase inverter. All parameters are adjusted for minimum distortion. This type of phase inverter has the unique advantage that its operation is independent of tube aging so that no adjustments are required in maintaining optimum performance.

An internal capacitive feedback loop balances the phase inverter at the highest frequencies, and the arrangement provides accurately balanced driving signals to the output tubes, which are EL-34's operated well below their maximum ratings. The output tubes use a fixed bias arrangement which is set through use of Dyna Biaset (patent pending) which provides optimum linearity of the tubes and minimizes the effects of unbalanced components. The connection of the output tubes includes a small percentage of screen loading which improves the regulation of the output stage and makes it comparatively uncritical of load impedance.

The impedance match and bias conditions utilized in the output stage provide minimum distortion over a very wide dynamic range. In addition, 20 DB of negative voltage feedback lowers the distortion to an unmeasurable proportion at normal listening levels and to less than 1% intermodulation distortion at 40 watts output.

The use of a minimum number of phase shifting stages along with careful transformer design makes it possible to have unconditional stability at both high and low frequencies. This feature of the design means that there is no tendency toward motorboating or oscillation under any condition of use.

The inherent linearity of the circuit, its absolute stability, and the prefabrication of all critical wiring on the printed circuit assembly make construction completely non-critical. The use of conservatively operated, highest quality components insures superior and dependable operation over a long period of time.

GENERAL WIRING PRACTICE

Assembly of the Dynakit Mark IV is quite simple compared to general kit assembly requirements. This is because all critical parts of the Dynakit are factory assembled for you on the printed circuit assembly. Other parts are out in the open in a free and uncluttered layout so there is easy accessibility for wiring or trouble shooting purposes. Construction of your Dynakit should not take more than three hours because of these simplifications.

Upon opening your kit, check the components with the parts list. Familiarize yourself with the components; they can be identified by comparison with the pictorial diagram and by specified color coding.

Tools required for easy assembly of your Dynakit are a soldering iron (small tip) or soldering gun, long nose pliers, screwdriver, and wire cutters. Although not essential, a low cost wire stripper and cutter of the type which can be purchased for less than a dollar will greatly facilitate cutting and stripping the various leads in the kit.

Good soldering technique is valuable in obtaining satisfactory results from any electronic equipment. **ALL SOLDERING MUST BE DONE WITH ROSIN CORE SOLDER.** There is no warranty on any equipment in which acid core solder has been used. Make sure that the solder is plainly marked "Rosin Core." If you have solder on hand the origin of which is doubtful, it is wise to obtain new 50/50 or 60/40 rosin core solder. Whenever soldering is required, the assembly instructions specify it by "(S)". If this symbol is not shown after a connection is specified, it indicates that further connections will be made at that point before soldering.

Soldering is accomplished by heating the joint with the iron until solder is hot enough to flow when touched to the joint. It is not desirable to feed the solder to the iron. It should be fed to the junction of iron and joint. After the solder flows, the iron should be held in place for a few seconds and removed when it is seen that the solder has contacted both parts of the connection—the lug and the wire connected to it. It should not show a ball of solder, but a smooth transition from solder to component lead.

Before applying solder the joint should be clean and the lead should be crimped in place so as to have mechanical security. It is not necessary to wrap leads around contacts many times. A single turn and pinching together with pliers is suitable. After soldering there should be no play at the joint if the lead is wiggled with a pair of pliers. It is practical to do all soldering with a pencil type iron with a low wattage rating. A small tip is extremely useful when working in confined space. If a soldering gun is used it *should* be used with *discretion* since the amount of heat available is far more than required for soldering light wires.

Component leads should be trimmed as they are used; the length should be such that the proper connection can be made from point to point without strain on lugs or components. Care should be exercised not to allow wires to touch one another unless they are actually connected to the same point.

The instructions which follow have been arranged for simplified procedure in which the work can be done without interference between the various portions of the wiring. It is recommended that the instructions be followed on a step by step basis, checking off each step as it is completed. The pictorial diagrams should be used for reference and all connections checked against these before going on to the next step. If the wiring is done methodically and each step checked carefully, your amplifier should work without difficulty as soon as it is completed.

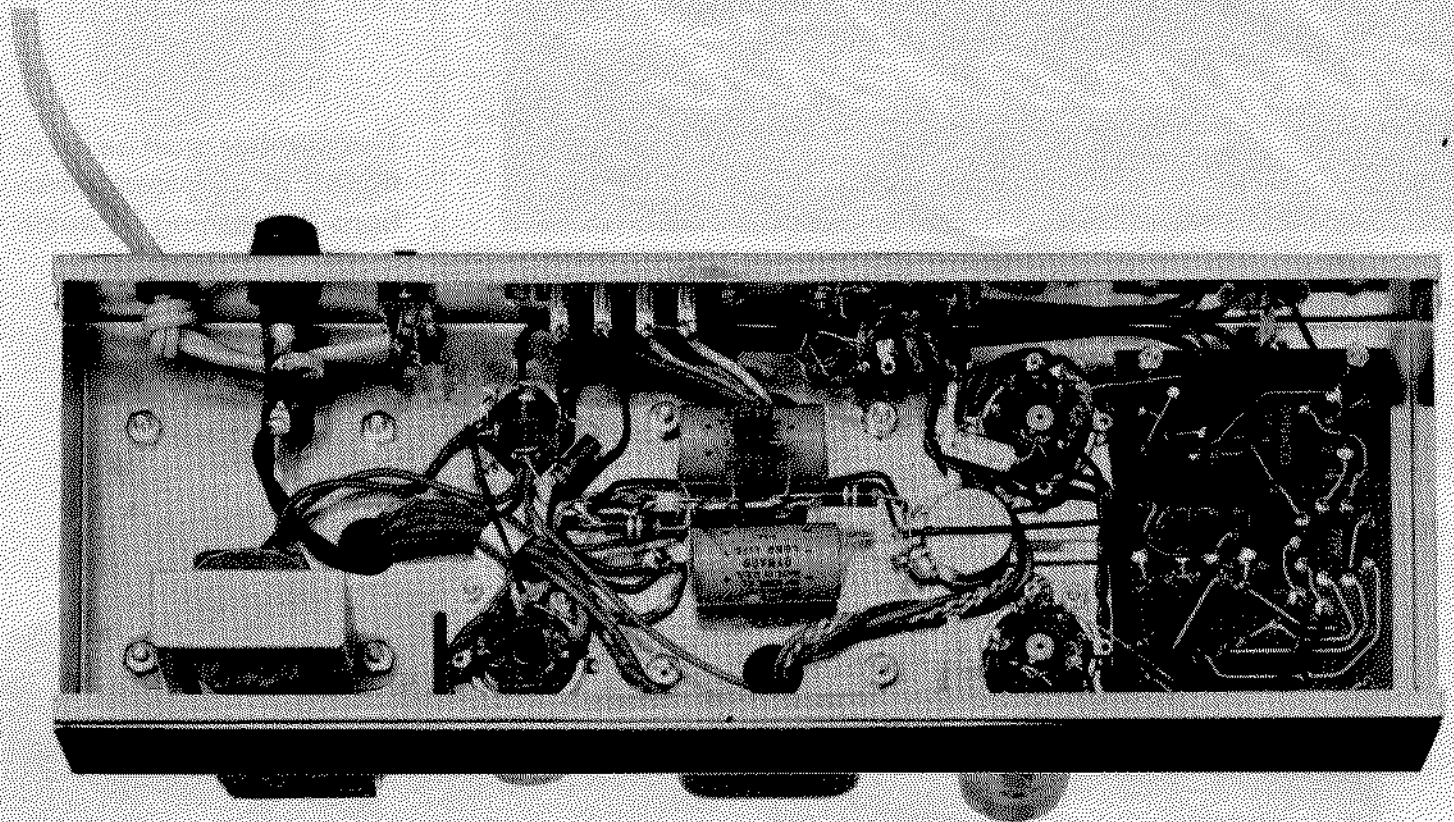

SPECIFICATIONS

Power output: 40 watts continuous, 90 watts peak

IM distortion: less than 1% at 40 watts, less than .05% at 1 watt

Frequency response: $\pm .5$ db from 10 cps to 40 kc;
 $\pm .5$ db from 20 cps to 20 kc at 40 watts output

Power response: 20 cps to 20 kc without exceeding 1% distortion within 1 db of 40 watts

Sensitivity: 1.3 volts rms input for 40 watts output

Hum and Noise: Inaudible; 90 db below 40 watts (choke filtering)

Damping Factor: 15

Output Impedances: 4, 8 and 16 ohms

Tubes: EL-34 (2), 7199, GZ-34, selenium rectifier

Finish: bright nickel chassis, vinyl coated charcoal brown cover

Special Features: Matched tubes, Dyna Biaset for non-critical adjustment, preamp power socket, fuse post, on-off switch

Power Consumption: 115 watts

Size: 5" x 14" x 6½" high

Weight: 20 pounds

MECHANICAL ASSEMBLY

Refer to Pictorial Diagrams for Location of Parts

- 1 () Mount the four octal sockets with #4 screws, nuts, and lockwashers (the smallest screws supplied). *Note* that there is a small slot or keyway in the center hole of each socket; be sure in each instance that this keyway is properly oriented as shown in the pictorial diagrams. Insert the screws from the top of the chassis and mount the sockets from the inside. Fasten each screw with a nut and lockwasher.
- 2 () Mount the input socket from the inside of the chassis using #4 screws, nuts, and lockwashers.
- 3 () Using #4 hardware, mount the four screw terminal strip on the *outside* of the chassis.
- 4 () Mount the slide switch from the inside with #4 screws. Nuts and lockwashers are not necessary in this instance. Follow the position of the connecting lugs in the pictorial.
- 5 () Mount the fuse post with the special nut provided. The rubber bushing goes on the outside of the chassis. *Note* that there is only one correct way for the post to be mounted.
- 6 () Insert the rubber grommet in the $\frac{3}{8}$ " hole at the end of the chassis.
- 7 () Mount the 10,000 ohm bias potentiometer in the $\frac{3}{8}$ " hole near the pair of octal sockets. Put the lockwasher on the shaft, insert the control in the hole and fasten at the top of chassis with the $\frac{3}{8}$ " nut. *Note* orientation of connecting lugs.
- 8 () Mount the five lug terminal strip and the solder lug at the center of the chassis. Insert a #4 screw from the outside. Place the terminal strip over the screw, then the small solder lug, then the #4 nut.
- 9 () With #4 hardware, mount the cable clamp *loosely* near the single octal socket.
- 10 () Feed all the wires of the power transformer, PA-135, through the single hole provided. Fasten the transformer in place with two #8 screws in the holes nearest the front of the chassis using #8 lockwashers and nuts. Now, from the bottom, place the choke over the remaining two transformer mounting holes and fasten both in place with two more sets of #8 hardware. All but the black transformer leads go under the cable clamp next to the rectifier socket; and then this clamp may be tightened.
- 11 () Mount the output transformer, A-470, on the remaining set of holes at the center of the chassis. *Note* that the black, brown, orange, and yellow leads come through

the hole near the four screw terminal strip. Use #8 hardware to secure the transformer.

- 12 () Mount the quadruple section filter capacitor in the special cutout. Observe the symbols at the base of each connecting lug. These should be oriented as shown in the pictorial. Fasten the capacitor by giving each of the mounting lugs a quarter turn while holding the capacitor snugly against the chassis.

WIRING INSTRUCTIONS

Each length of hookup wire specified should have approximately $\frac{1}{4}$ " of insulation stripped from each end unless otherwise specified. Transformer leads may be trimmed as required for a neat wiring job.

- 1 () Connect one of the black power transformer leads to lug #2 of the slide switch (S). Connect the other black lead to lug B of the fuse post (S).
- 2 () Connect one yellow power transformer lead to pin #2 of socket V1 (S). Connect the other yellow lead to pin #8 of socket V1.
- 3 () Twist the two red leads together and position them around socket V1. Connect one red lead to pin #4 (S). Connect the other red lead to pin #6 of V1 (S).
- 4 () Twist the two green power transformer leads together and position them to socket V2. *SEE PICTORIAL*. Connect one green lead to pin #2 of socket V2, and the other green lead to pin #7 of V2.
- 5 () Connect the green/yellow lead to lug #2 of the five lug terminal strip.
- 6 () Connect the red/yellow lead to solder lug at the mounting screw of the five lug strip.
- 7 () Connect the red/black lead to lug #4 of the five lug strip.
- 8 () Connect one choke lead to lug #1 (semi-circle) of the quad filter capacitor. Connect the other choke lead to lug #2 of the filter capacitor.
- 9 () Connect the black lead of the A-470 output transformer to lug #1 of the four screw terminal strip. Connect the brown lead to lug #2 (S). Connect the orange lead to lug #3 (S). Connect the yellow lead to lug #4.
- 10 () Connect the red output transformer lead to lug #2 of the filter capacitor. Twist the remaining leads together and carry them to sockets V2 and V3. *SEE PICTORIAL*. Connect the blue/white lead to pin #3 of socket V2 (S). Connect the green/white lead to lug #4 of socket V2

- (S). Connect the blue lead to pin #3 of V3 (S). Connect the green lead to pin #4 of V3.
- 11 () Connect one end of a 10,000 ohm (brown-black-orange) resistor to lug #5 of the five lug strip. Connect the other end to lug #1 of the 10,000 ohm bias potentiometer (S).
 - 12 () Connect the positive (+) end of the selenium rectifier to lug #4 of the five lug strip (S). Connect the negative (-) end to lug #5 of the strip.
 - 13 () Connect the negative (-) end of a 50 mfd bias capacitor to lug #5 of the five lug strip (S). Connect the positive (+) end to lug #3 of the strip.
 - 14 () Connect the positive (+) end of the other 50 mfd bias capacitor to lug #3 of the five lug strip. Connect the other end to lug #2 of the 10,000 ohm bias potentiometer.
 - 15 () Connect one end of a short piece of wire to lug #2 of the five lug strip (S). Connect the other end to lug #3 of the strip. If the amplifier is to be used with a Dynakit PAM-1 (monophonic) preamplifier, this wire should be omitted and lug #2 soldered.
 - 16 () Connect one end of a 10,000 ohm (brown-black-orange) resistor to lug #3 of the five lug strip (S). Connect the other end to lug #1 of the strip.
 - 17 () Connect one end of a 4½" wire to lug #1 of the five lug strip (S). Connect the other end to lug #3 of the bias control potentiometer (S).
 - 18 () Connect one end of a 2½" wire to a mounting lug (ground lug) of the filter capacitor (S). Connect the other end to solder lug at mounting screw of the five lug strip.
 - 19 () Strip ½" of insulation from each end of a 5" wire. Feed one end through pin #8 of socket V2 (S) and connect to pin #1 (S). Feed the other end through pin #8 of socket V3 and connect to pin #1.
 - 20 () Connect one end of a 2" wire to pin #1 of V3 (S). Connect the other end to pin #8 of power takeoff socket (on front side of chassis) (S).
 - 21 () Connect one end of the 13.5 ohm resistor to pin #8 of V3 (S). Connect the other end to ground lug of socket V3 (S). SEE PICTORIAL.
 - 22 () Connect one end of a 3" wire to pin #8 of socket V1 (S). Connect the other end to lug #1 of the quad filter capacitor (S).
 - 23 () Connect one end of a 4" wire to lug #1 of the four screw terminal strip (S). Connect the other end to ground lug at the five lug strip (S).
 - 24 () Twist together a pair of 5" wires and connect one end of one to pin #2 of V2. Connect the corresponding end of the other to pin #7 of V2. Connect one of the other ends to pin #2 of V3, and connect the last one to pin #7 of V3.
 - 25 () Twist together a 5½" and a 4½" wire so that one pair of ends are uneven. Connect the even pair of ends to pins #1 (S) and #2 (S) of the power takeoff socket. Connect the long end to pin #2 of V3 (S). Connect the remaining end to pin #7 of V3 (S).
 - 26 () Connect one end of a 10 ohm (brown-black-black) resistor to pin #3 of the power takeoff socket (S). Connect the other end to ground lug at that socket (S).
 - 27 () Connect one end of a 22,000 ohm resistor (red-red-orange) to pin #5 of the power takeoff socket (S). Connect the other end to pin #4.
 - 28 () Connect one end of a 5½" wire to pin #4 of the power takeoff socket (S). Connect the other end to filter capacitor lug #4. (See application notes if other than DYNA preamp is to be used.)
- Mount the printed circuit board in the cutout at the end of the chassis. Note that the socket is located nearest the end of the chassis. The board should be mounted from the *bottom* of the chassis with #4 screws, nuts, and lockwashers.
- The eyelets on the printed circuit board already have solder in them. Each eyelet has a number which will be referred to in the instructions. Before making a connection to the board, "tin" the stripped wire to be connected by heating with the soldering iron and touching solder to it. To solder to the eyelet, heat the eyelet with the iron, insert the wire when the solder in the eyelet flows, remove the iron and allow a few seconds for the solder to set. Although the metal eyelet does protect the printed wiring from overheating, a small iron should be used to avoid excessive heat on the printed circuit board.
- 29 () Connect one end of a 2" wire to eyelet #1 of the circuit board (S). Connect the other end to the ground (short) lug of the input socket (S).
 - 30 () Connect one end of a 2" wire to input socket long lug (S). Connect the other end to eyelet #2 (S).
 - 31 () Twist together a pair of 6" wires. Connect one end to pin #2 of V2 (S). Connect the other end to pin #7 (S). Connect one of the other ends to eyelet #4 (S). Connect the remaining end to eyelet #5 (S).

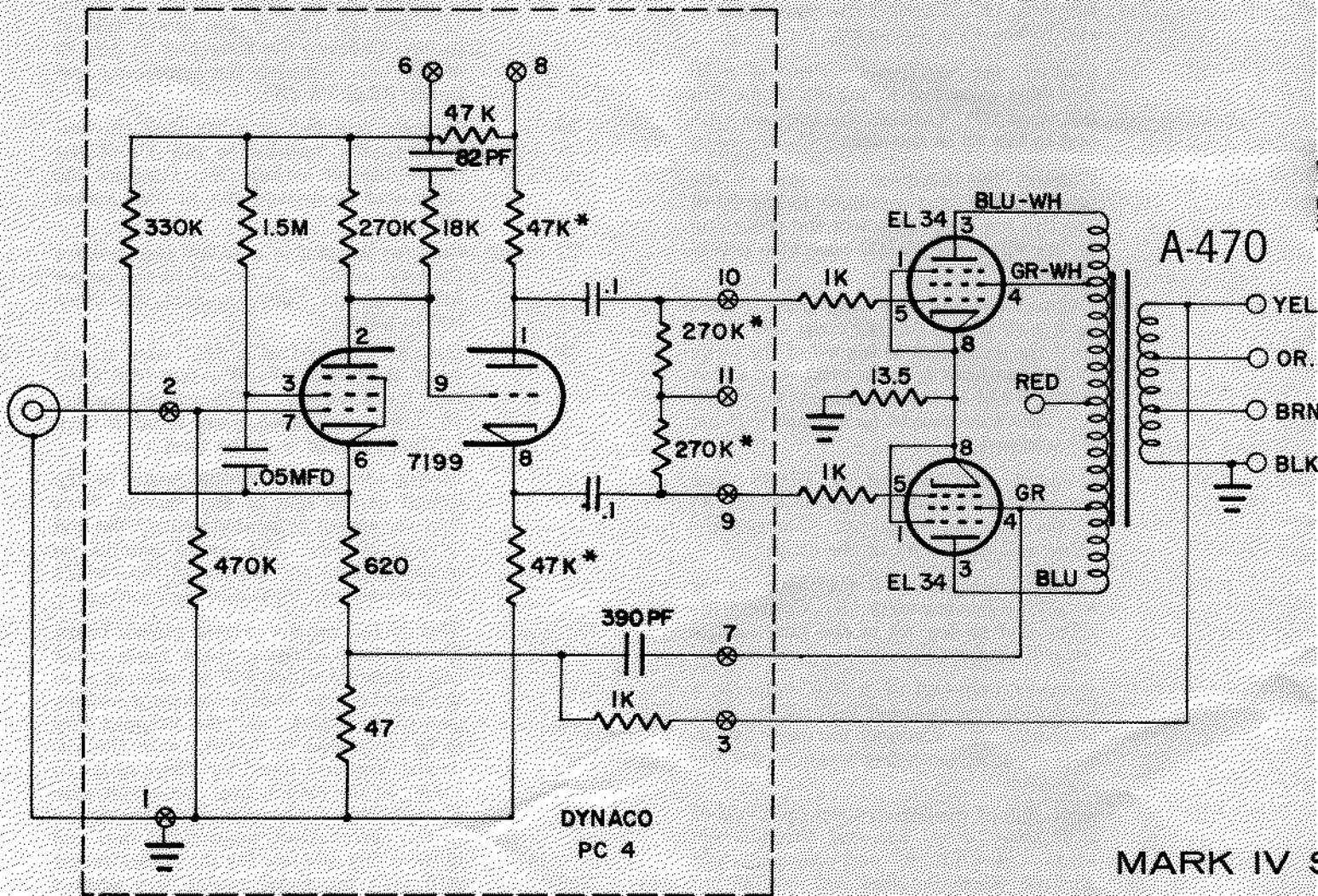

* MATCHED PAIRS

MARK IV S

16
3
4
COM.

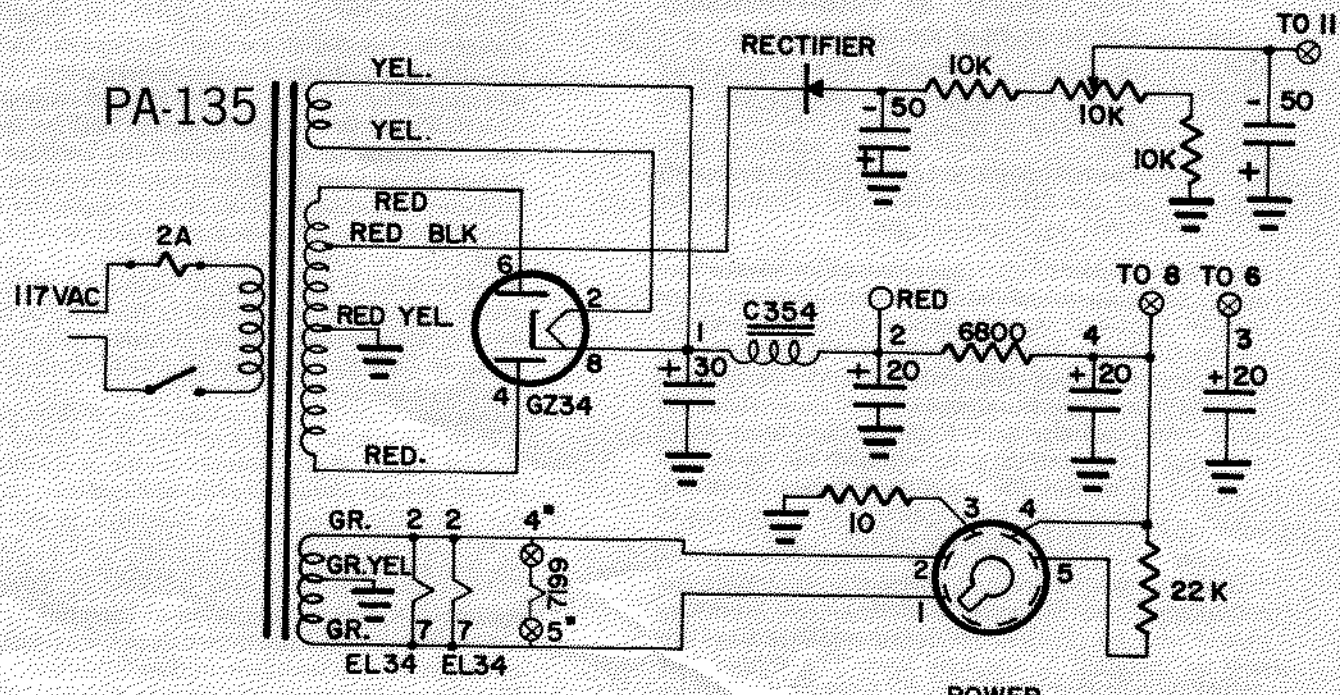

SCHEMATIC

* 4 & 5 EYELETS ON CIRCUIT BOARD.

POWER TAKE OFF SOCKET

- 32 () Connect one end of a 7" wire to lug #4 of the four screw terminal strip (S). Connect the other end to eyelet #3 (S).
- 33 () Connect one end of a 1000 ohm (brown-black-red) resistor to eyelet #9 (S). Connect the other end to pin #5 of socket V3 (S).
- 34 () Connect one end of a 3½" wire to lug #2 of the bias potentiometer (S). Connect the other end to eyelet #11 (S).
- 35 () Connect one end of a 1000 ohm (brown-black-red) resistor to lug #5 of V2 (S). Connect the other end to eyelet #10 (S).
- 36 () Connect one end of a 3½" wire to pin #4 of V3 (S). Connect the other end to eyelet #7 (S).
- 37 () Connect one end of a 6800 ohm (blue-gray-red) resistor to lug #2 of the quad filter capacitor (S). Connect the other end to lug #4 of the filter capacitor.
- 38 () Connect one end of a 10" wire to lug #4 of the filter capacitor (S). Connect the other end to eyelet #8 (S).
- 39 () Connect one end of an 11" wire to lug #3 of the filter capacitor (S). Connect the other end to eyelet #6 (S).
- 40 () Separate the two conductors of the line cord for about 2½". Cut about 1" from one of the conductors, then strip and tin both. Insert the line cord through the grommet from the outside and push enough through to tie a knot about 4" from the end. Pull the cord back until the knot is snug against the grommet. Connect the short lead to lug A of the fuse post (S). Connect the other lead to lug #1 of the slide switch (S).

It is wise to go back and check all connections for correctness and for good soldering. All hardware should also be checked for tightness. The fuse can now be installed in the fuse post. The rubber feet should be installed in the proper holes in the bottom of the bottom plate.

INITIAL ADJUSTMENT

Plug in the EL-34's (see pictorial) and the 7199 tube. Do not plug in the GZ-34/5AR4 rectifier yet. If an ohmmeter is available measure the resistance from capacitor lug #2 to ground (chassis). This should be in excess of one hundred thousand ohms. Inspect wiring to make sure that all joints are soldered and that no parts are shorting together. Plug line cord into 117 volt AC outlet and turn on switch. While tubes are warming up, set the bias potentiometer to the approximate center of its rotation. This setting is only approximate and the amplifier should not be run without following the directions below.

Your Dynakit includes Dyna Biaset (patent pending) which greatly simplifies setting of the bias voltage. This can be done with the most simple and inexpensive types of DC meters as long as they have a

rating of 1000 ohms per volt or higher. The correct setting of the bias provides a total cathode current of 115 MA for the pair of EL-34's. This current through the precision 13.5 ohm resistor produces a voltage drop of exactly 1.56 volts DC, and this voltage can be checked at pin #8 of the preamplifier power takeoff socket. 1.56 volts is the voltage reading of a new type D flashlight cell. Thus any fresh type D cell may be used for an accurate reference for the bias voltage setting.

The procedure for setting the bias voltage is to measure the voltage of a fresh type D cell and note the meter indication. Then insert the positive meter probe in the pin #8 hole of the preamp takeoff socket. (Note that outside the chassis the pin numbers are counted counter-clockwise from the key.) The negative meter probe should be applied to the chassis. Plug in the GZ-34/5AR4 rectifier tube, and in about ten seconds there will be a current flow which will cause an indication on your meter. The bias potentiometer should be adjusted until the meter indicates the same voltage as did the type D cell. There may be a slight drifting of the voltage indication as the new amplifier warms up for approximately the first 15 minutes, after which the bias control may be readjusted. Thereafter slight variations may be caused by small changes in the supplied line voltage. These variations will neither affect the performance of the unit, nor will it be necessary to readjust the bias setting. The bias setting is a semi-permanent one and need only be reset upon replacement of the output tubes or at such time as other repairs or maintenance might be required. A recheck at the time of maintenance, or after a year or more of heavy usage, will help preserve peak performance and keep distortion to an absolute minimum.

If in the course of bias setting it is found that the control range of the potentiometer is insufficient to obtain the correct setting, do not operate the amplifier until the cause of the difficulty is determined. Operation with incorrect bias can lead to damage of the output tubes and/or other components.

Note that the use of pin #8 as directed in the wiring instructions means that this pin may not be used as a connection for power takeoff for preamplifiers. Most preamplifiers do not require the use of this pin; however if use of pin #8 is indicated for your particular preamplifier, another unused pin must be chosen for a bias voltage check point. If this is not possible, the connection from the output tube pin #8 to the power takeoff socket must be omitted; the bias voltage meter reading may then be made directly at the #8 pin of either output tube.

PREAMPLIFIERS

The Dynakit Mark IV can be used with any conventional preamplifier in monophonic or stereo systems. Preamplifiers which are self powered are connected by simply plugging the signal or audio cable into the input socket of the Mark IV. Preamplifiers which are dependent on a power amplifier for their power source are readily connected to the preamp power takeoff octal socket on the Mark IV. The Mark IV wiring instructions include the correct power takeoff connections for both the DYNAKIT PAM-1 pre-

amplifier and the Heathkit WA-P2. Should other units with different power plug wiring be used the takeoff socket may be rewired to suit requirements. The wire jumper between lugs #2 and #3 of the 5 lug terminal may have to be cut depending on the type of preamp to be used. This jumper should be cut for use when powering a Dynakit PAM-1 preamplifier or Heathkit WA-P2 or any other preamplifier which requires power from a "floating" or ungrounded heater supply. The jumper should not be cut when using any preamplifier which has its own, or a separate, power supply.

PROTECTIVE COVER

The protective cover supplied with the MARK IV has been designed to be both functional and attractive. In normal home usage the cover should always be used; although the voltage at the top of the printed circuit is not lethal, an unpleasant shock can be experienced, plus the fact that the tubes in normal operation run hot enough to produce a minor burn if touched.

The amplifier should be located where there is ample ventilation—at least one foot of space above it and several inches all around. The amplifier can be located away from other elements of your system so there is no need to place it in a confined area. Never place anything directly on the cover which might limit the ventilation. It is always advisable to operate the amplifier in its normal vertical position.

The cover and bottom plate are attached at the same time. Place the amplifier on the bottom plate, then lower the cover over the unit, the tabs on the cover will fit between the ends of the bottom plate and the chassis. The three pieces are fastened simultaneously with sheet metal screws through the sides.

IN CASE OF TROUBLE

Your Dynakit MARK IV has been conservatively designed to be as trouble free as possible. Error in assembly or possibly a defective component may affect performance or render it inoperative. Here are some suggestions which may help. First of all the wiring and assembly should be doubly checked, by someone other than the constructor if possible.

The tubes should light a few seconds after the unit is turned on. If not, miswiring or a blown fuse will probably be the answer. Replace a blown fuse only with the type (2 ampere) originally supplied.

If the fuse blows when all tubes are removed from sockets a defective power transformer or miswiring is indicated.

If one or the pair of EL-34 output tubes glow a cherry red after warm-up, it is possible that a tube is defective, or there may be a fault in the bias supply which controls the current flow of the output tubes. When the biaset reading is 1.56 volts the bias voltage at the grids (pins 5) of the output tubes should be within 20% of 34 volts NEGATIVE. A VTVM or high impedance meter must be used here. If the voltage at each of the grids is not exactly the same, one of the .1 mfd coupling capacitors on the printed circuit board may be at fault. If one tube has no negative

voltage at pin #5, an open circuit exists between the tube and bias supply.

If no meter is available and one tube glows, interchanging the two tubes will help indicate the fault. If the same tube glows in the other socket, the tube is at fault. If the other tube glows in the original socket position then wiring or components are at fault.

The output tubes supplied with your MARK IV are carefully matched at the factory. When replacing output tubes a matched pair should be used, or a new one should be matched to the remaining good one.

In emergencies, substitution of tubes can be made. Type 5881 or KT66 may be used in place of EL-34's provided the bias is readjusted for these tubes. Type 5U4 or 5U4GB can be substituted for the GZ-34/5AR4 rectifier. Either of these substitutions will result in somewhat lowered power output, however. There is at present no substitute for the 7199 tube.

No Signal

If the momentary insertion of a small screw driver in the input socket causes a loud hum, the trouble is probably in the associated equipment. If the amplifier is at fault, testing or substitution of tubes may help. Voltages may be checked in accordance with the voltage chart provided in the instructions.

Hum and Noise

If excessive hum or noise is apparent, it is essential to determine whether the disturbance is from the power amplifier or associated equipment. Power amplifiers are often blamed for noise coming from the preamp. The quick and simple way to determine this is to remove all but the speaker from the amplifier. If the hum or noise disappears, the noise comes from other than the amplifier; if it persists, it can safely be assumed it is in the unit.

Sizzling sounds may be caused by poor solder connections and occasionally by a defective resistor. Loud cracking or popping sounds are generally caused by loose tube elements and in rare cases a defective quad section filter capacitor.

In the event that the trouble cannot be found, factory consultation is available at no charge and service at moderate fees.

FACTORY SERVICE AND GUARANTEE

The MARK IV is designed to provide good service for a long time. It is intended for operation at the conventional 117 volt line voltage supply to most homes and may be operated at up to 125 volts without problems. Operation with line voltage above 125 volts will shorten tube and component life, and is not covered by the guarantee.

All parts in the MARK IV are guaranteed for a period of one full year from purchase date with the exception of the tubes which are covered by the standard EIA guarantee of 90 days. Defective parts will be replaced at no charge if they are returned prepaid directly to the factory or through the dealer from whom the kit was purchased. Many DYNACO dealers stock parts for convenience of replacement. After the guar-

antee period, DYNACO will replace any non-standard parts at net prices. Many of the components are standard items which can be purchased from most electronic supply stores.

If transformers are returned for factory repair or replacement, they should be removed from the equipment without cutting leads short. If leads are cut rather than unsoldered so that they are unusable, the transformer guarantee is void.

In the event the assembled kit does not function properly or breaks down after use, DYNACO will service the kit for a fee of \$5.00 plus the cost of parts which have been damaged or are past guarantee. This service facility is not available for kits which are incompletely wired or which have been wired with other than rosin core solder, or in which changes have been made without factory authorization. In addition, **NO PARTS WILL BE REPLACED NOR WILL ANY SERVICE BE RENDERED FOR KITS WHERE THE GUARANTEE POST CARD HAS NOT BEEN RETURNED. THE SERIAL NUMBER ON THIS INSTRUCTION BOOK MUST BE MENTIONED IN CORRESPONDENCE, PARTS RETURN, OR KITS RETURNED FOR FACTORY SERVICE.** It is the factory prerogative to limit the service facility to one year from date of purchase.

When shipping a unit for service, a note must be attached specifying symptoms, the name and address of the sender, and the serial number of the unit. The amplifier should be securely packed with stuffing inside the cover to prevent the tubes from coming out

of their sockets in shipment. It should be placed in a rugged carton and surrounded with plenty of shock absorbing packing material. The original carton is not suitable for shipping an assembled amplifier.

Shipping should be by Railway Express, prepaid; repaired kits will be returned by Railway Express collect for shipping and service charges unless these are prepaid. Parcel post is not a safe method of shipment for assembled units.

Dyna Co. assumes no responsibility or liability for damages or injuries sustained in assembly or operation of the DYNAKIT.

MARK IV VOLTAGE CHART

VI rectifier GZ34	V2 & V3 EL34	V4 7199
Pin		
1	1.56 DC	290 DC
2 440 DC	6.3 AC	140 DC
3 —		42 DC
4 370 AC		—
5 —		1.5 DC
6 370 AC		—
7 —	1.56 DC	145 DC
8 440 DC		140 DC
9		

*This negative voltage must be measured with a VTVM only.

All measurements on this chart were made with a VTVM. Other types of meters may give a lower indication in some cases.

PARTS LIST

Parts of similar type which do not change performance may sometimes be included as a matter of expediency. This will account for slight variations in value and appearance.

- 1 Chassis set (including cover and bottom plate)
- 1 Power transformer—PA-135
- 1 Output transformer—A-470
- 1 Choke—C-354
- 2 Output tubes—EL-34 6CA7
- 1 Rectifier tube—GZ-34 5AR4
- 1 Driver tube—7199
- 4 Octal sockets
- 1 Printed circuit assembly—PC-4
- 1 Filter capacitor (quad @ 525 Volts)
- 2 Capacitors (50 MFD)
- 1 Selenium rectifier—Cube
- 1 Four screw terminal strip
- 1 Fuse post with rubber washer and mounting nut
- 1 Fuse 2A
- 1 Line cord
- 1 Switch—SPST
- 1 Input socket
- 1 Potentiometer—10,000 ohms
- 1 Five lug terminal strip
- 1 Hank of wire

RESISTORS

- 1 13.5 ohm precision
- 2 1000 ohm (brown-black-red)
- 2 10,000 ohm (brown-black-orange)
- 1 10 ohm (brown-black-black)
- 1 6800 ohm (blue-grey-red)
- 1 22,000 ohm (red-red-orange)
- 1 Solder lug
- 1 3/8 nut
- 1 3/8 lockwasher
- 1 Cable clamp
- 8 #8 machine screws
- 8 #8 lockwashers
- 8 #8 nuts
- 19 #4 machine screws
- 16 #4 lockwashers
- 17 #4 nuts
- 4 Rubber feet
- 1 Rubber Grommet
- 4 Sheet Metal Screws #6
- 1 Set of instructions and warranty card

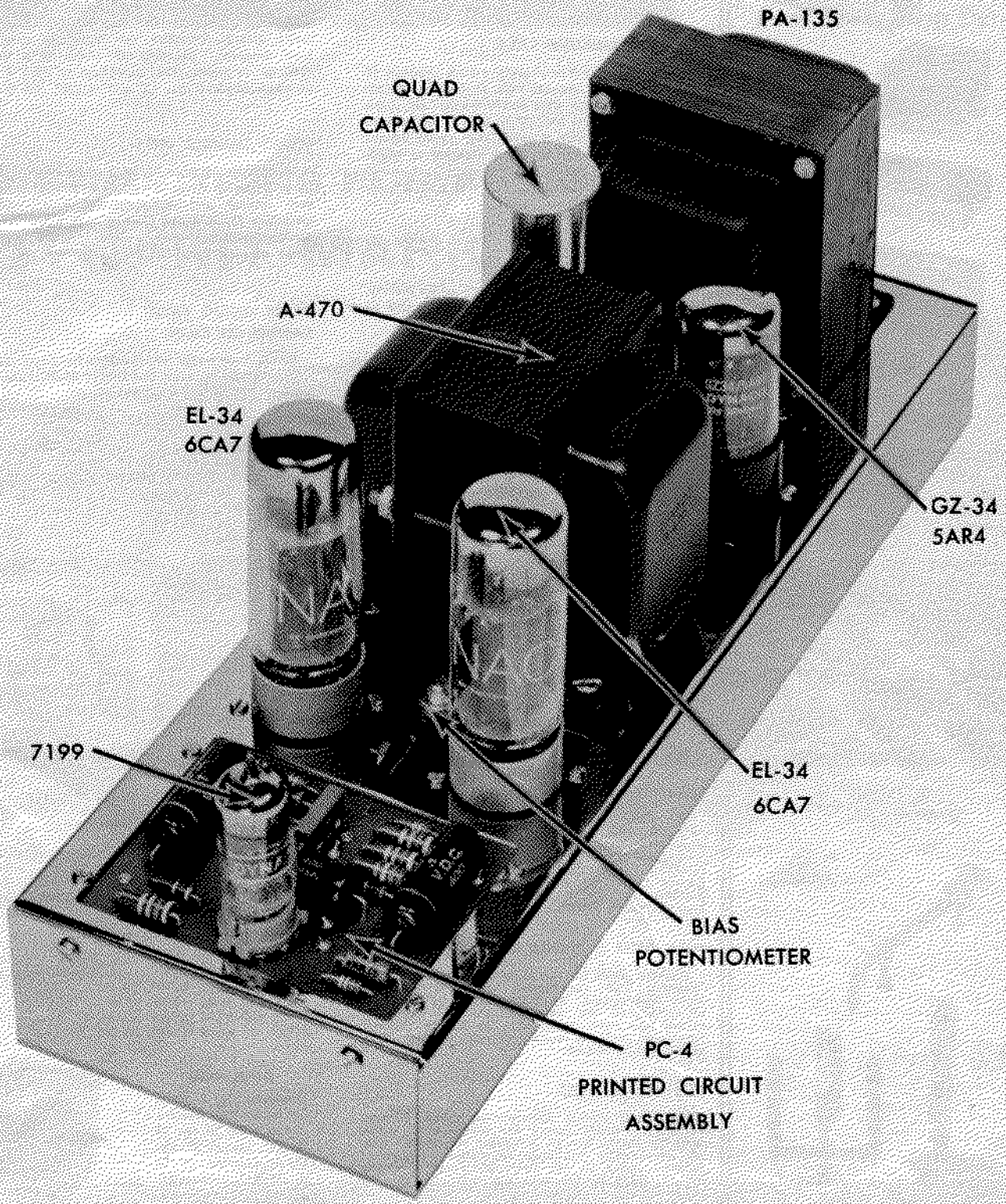

PA-135

QUAD
CAPACITOR

A-470

EL-34
6CA7

GZ-34
5AR4

7199

EL-34
6CA7

BIAS
POTENTIOMETER

PC-4
PRINTED CIRCUIT
ASSEMBLY